

# X-GRIP MINI M

ORDER NUMBER: 0050.2520

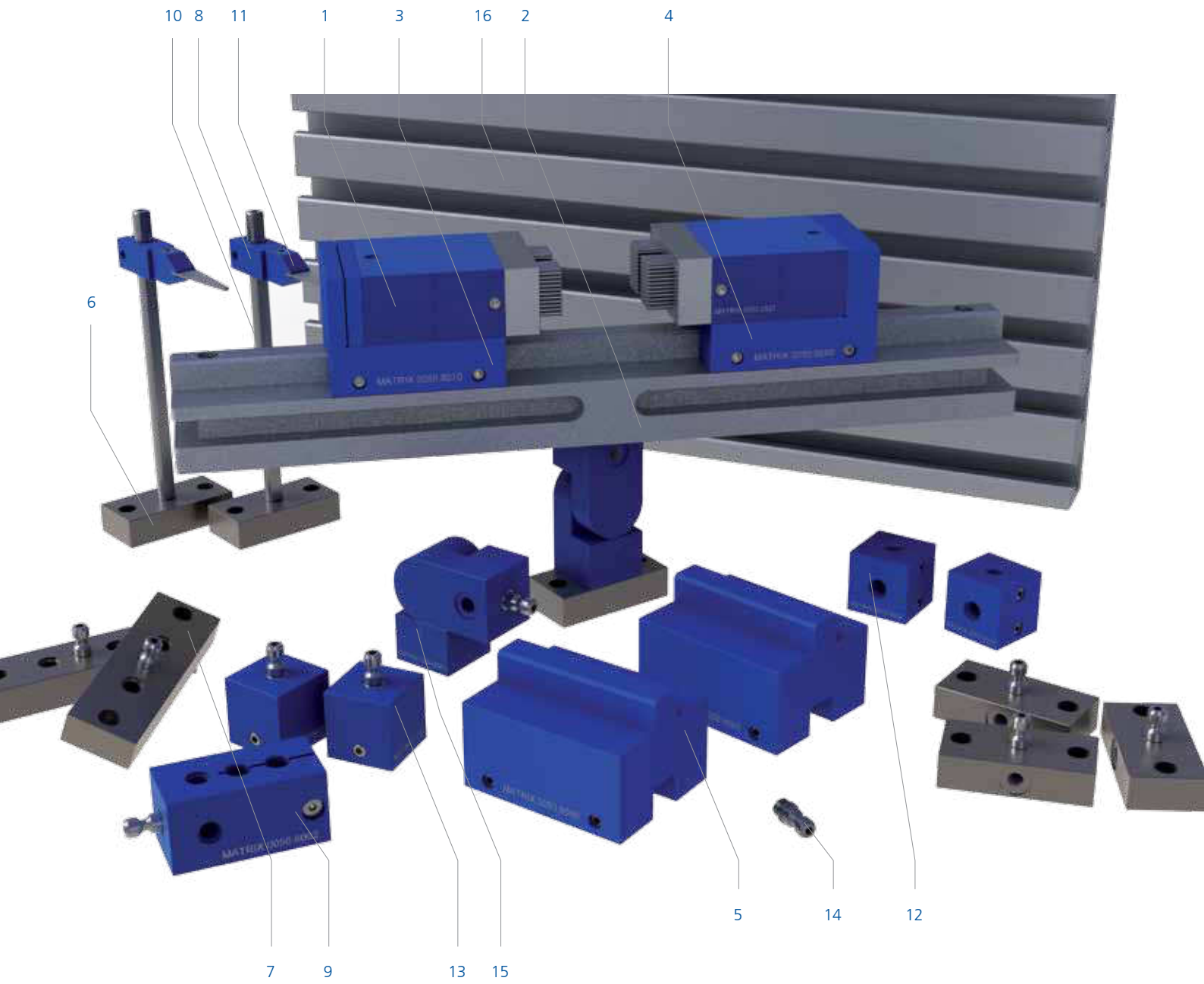

## X-GRIP MINI M

The X-GRIP MINI M is a form-closure and fast holding system with two pin-jaws for filigree and lightweight parts with unsurpassed resolution (1 mm pin diameter).



17

The modular system consists of the following individual components:



Fig.	Article no.	Quantity	Description	Dimension / info	Pin field	Number of pins	Pin diameter	Pin stroke
1	0050.2527	2	X-GRIP MINI Module, double	20 x 40 x 50 mm	14 x 11 mm (x2)	252	1 mm	7.5 mm
Further information about the module:				Weight: 132g, Clamping screw: Hexagon SW2, Material pins: Stainless steel, Material housing: Aluminium anodized, Adaption: Connection pin Ø 5, Instalation location: any, Air connections for cleaning, Data sheet on request				
2	0050.8010	1	Guide rail	250 mm	–	–	–	–
3	0050.8070	1	Carriage, adjustable	–	–	–	–	–
4	0050.8080	1	Carriage, fixed	–	–	–	–	–
5	0050.8060	2	Height adjustment	25 mm	–	–	–	–
6	0050.8009	6	Base plate single	–	–	–	–	–
7	0050.8008	2	Base plate double	–	–	–	–	–
8	0050.8003	2	Holder, single	–	–	–	–	–
9	0050.8002	1	Holder, double	–	–	–	–	–
10	0050.8052	2	Holding rod	100 mm with scale	–	–	–	–
11	0050.8050	2	Pressure pad	–	–	–	–	–
12	0050.8007	2	Double-joint	90°	–	–	–	–
13	0050.8001	2	Adapter	20 mm	–	–	–	–
14	0050.8013	15	Connection pin with hexagon	M5	–	–	–	–
15	0050.8040	1	Knuckle joint - infinitely variable	–	–	–	–	–
16	0900.0200	1	T-slot profile plate	250 x 200 x 20 mm Slot width: 8 mm	–	–	–	–
17	0900.1000	1	Micro-screwdriver	–	–	–	–	–
–	0900.2503	1 Set = 16 Pcs	Set of fastening parts for X-GRIP MINI	–	–	–	–	–
–	0900.9005	1	MATRIX case for MINI CLAMP	–	–	–	–	–



